

# Manual for Rehabilitation Work of Irrigation Facilities

(Check Points for Better Design and Construction)

(Ver.1.0)

for

Technical Cooperation for Capacity Development  
for the Promotion of Irrigation Scheme Development  
under the District Agriculture Development Plans (DADPs)



April 2016

National Irrigation Commission, Ministry of Water and Irrigation (MoWI)

## Table of Contents

	Page
1. Introduction .....	1
1.1 Background .....	1
1.2 Objective .....	1
1.3 Scope of the manual .....	1
1.4 Relation to relevant Guideline and manuals .....	2
2. Procedure of the rehabilitation work .....	3
3. Check points for better design and construction .....	6
3.1 Design part .....	6
3.1.1 Design of apron .....	6
3.1.2 Canal protection against flooding .....	10
3.1.3 Characteristics of black cotton soil .....	11
3.1.4 Depth of embedment of a structure .....	12
3.1.5 Base concrete work for canal protection .....	13
3.1.6 Catch drain .....	14
3.1.7 Effective good use of existing structure and material .....	15
3.1.8 Unlined canal .....	16
3.1.9 Consideration to a way of cattle .....	17
3.2 Construction part .....	18
3.2.1 Earth work .....	18
3.2.2 Concrete work .....	21
3.2.3 Masonry work .....	24
3.2.4 Keeping materials tidy and in order around construction site .....	26
3.2.5 Installation of the construction guide bar .....	28
3.2.6 Supervision of construction .....	29
3.2.7 Records of construction .....	30
4. Example of cause analysis (Case study of Phase I) .....	32
4.1 Head Work .....	32
4.1.1 Base concrete washed away (Kimbande, Nyasa, Mtwara) .....	32
4.1.2 Side wall collapsed (Kimbande, Nyasa, Mtwara) .....	33

4.2	Canal	
4.2.1	Bulging of main canal sides and cracks on slab joints (Mbalangwe, Morogoro, Morogoro)	34
4.2.2	Collapse of main canal slabs (Mbalangwe, Morogoro, Morogoro)	35
4.2.3	Destruction of main canal (Mtawatawa, Liware, Mtwara)	36
4.2.4	Some fields do not efficiently get water (Mtawatawa, Liware, Mtwara)	37
4.2.5	Collapsed of sides on main canal (Minepa, Ulanga, Morogoro)	38
4.2.6	Scouring along the footpath (Kiyulini, Mwanga, Kilimanjaro)	39
4.2.7	Collapsed of secondary canal (Dakawa, Mvomero, Morogoro)	40
4.2.8	Vertical wall of the distribution boxes collapsed to the inside (Igongwa, Misungwi, Mwanza)	41
4.2.9	Collapse of division box (Minepa, Ulanga, Morogoro)	42
4.3	Others	43
4.3.1	Frequent bleaching of main canal banks (Lusu, Nzega, Tabora)	43
4.3.2	Destruction of vented drift (Bkigi, Maswa, Mwanza)	44

## 1. Introduction

### 1.1 Background

In Tanzania, there is an area of 29.4 million ha with the irrigation potential, and among them the area having high irrigation potential is 2.3 million ha (National Irrigation Master Plan, 2002). On the other hand, Tanzanian government had promoted the irrigation development under Agricultural Sector Development Program: ASDP, and the irrigation area spread to approximately 460,000ha (2014) and reached almost 20% of high irrigation potential area as a result.

However, some of the irrigation facilities have been damaged after a few years of their completion for various reasons, and agricultural production from the projects has regressed to the previous lower level. In this regard, it is necessary to promptly restore the function of irrigation facilities to higher level, otherwise damaged facilities will become irretrievable, and higher rehabilitation cost and new project cost may strain the Government resources.

### 1.2 Objective

Various problems that cause damages and malfunction to the irrigation facilities are monitored and their sources are analyzed in the field investigation. Continuously findings in the analysis are reflected to facilities planning, design and operation and maintenance methods in consideration of the present operation and management situation of facilities.

Meanwhile, the shortage of the engineers and construction materials has been pointed out in the investigation report for establishment of detailed plan in TANCAID II (Tanzania Capacity Building for Irrigation Development (Technical Cooperation for the Capacity Development for the Promotion of Irrigation Scheme Development under the DADPs)), but it was clarified that proper rehabilitation work could not be continuously implemented with practicable design and construction manuals/ guideline.

On the occasion of the review, problems such as weak foundation, deficiency of the irrigation water, lack of section dimension are to be clarified and the rehabilitation work are implemented while taking the local situation into consideration.

### 1.3 Scope of the manual

This manual picks up the check points for design and construction of irrigation facilities and the points given in here are extracted from past example in Tanzania and Japanese criteria. Moreover, this manual covers rehabilitation works performed in TANCAID I such as head work, open canal, division structure and so on.

#### 1.4 Relation to relevant Guidelines and manuals

The Guidelines consist of the main part and reference materials. The former shows the process of the procedure for Formulation, Construction, O&M and training. The latter collects a series of technical standard to supplement the main body.

The Rehabilitation manual improves the ability of Zonal Irrigation Offices and Districts staff by being made as Technical Guidance in the Comprehensive Guidelines. (Figure 1-1)

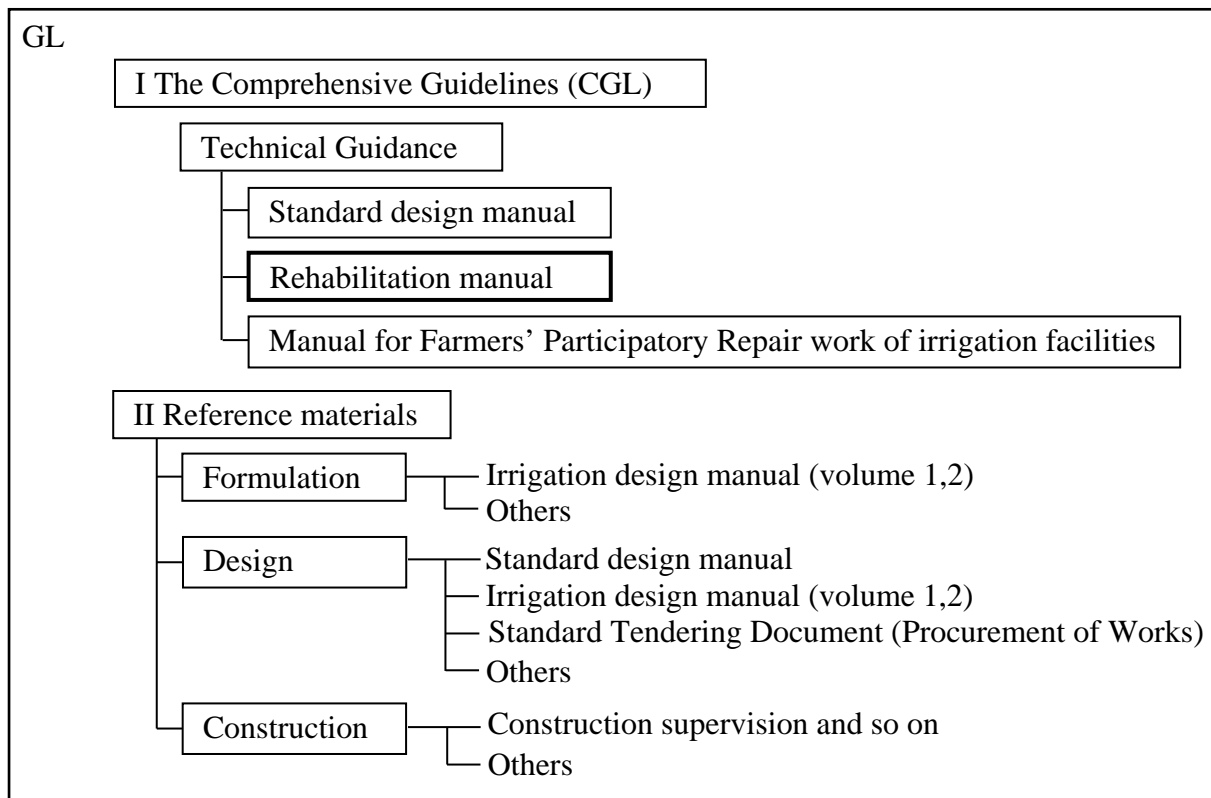

Figure 1-1 Relation to relevant guidelines

## 2. Procedure of the rehabilitation work

The rehabilitation work shall be performed along flow chart as shown in Figure 2-1.

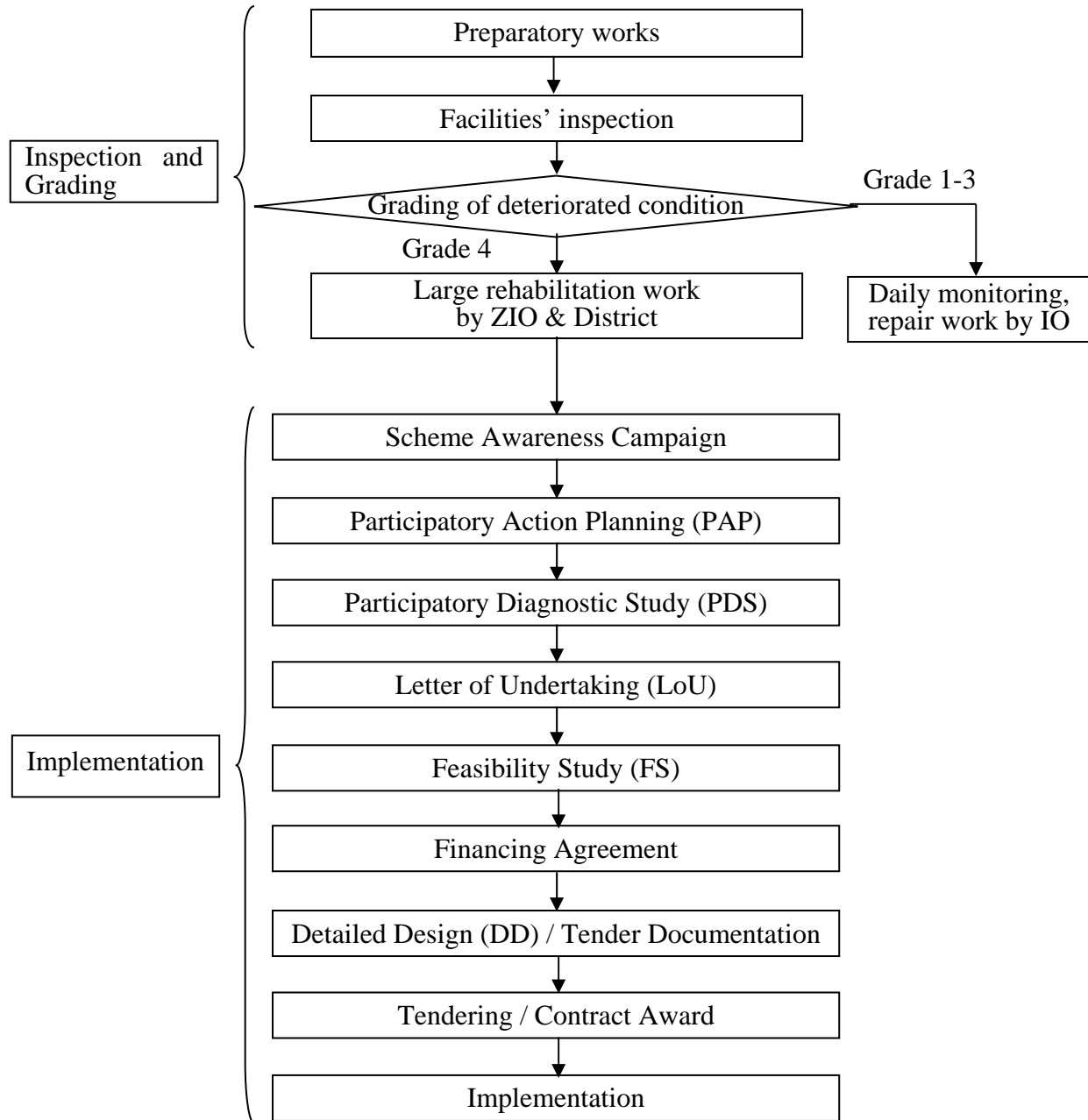

Figure 2-1 Procedure of rehabilitation work

Examination item in each step of Section 3 is as follows.

## 1 Inspection and Grading

Facilities' inspection shall be performed according to "Manual for Farmers' Participatory Repair work of irrigation facilities", 2013 and then, grading of deteriorated condition should be considered with each irrigation facilities.

When deteriorated condition of the facility is evaluated as grade 4, ZIO and District should establish the rehabilitation plan. On the other hand, the facilities evaluated as grade 1 to 3 shall be performed as daily maintenance or small repair works by IO.

## 2 Implementation

The rehabilitation plan should be established according to Section 3 of CGL.

However, Step 3: Participatory Diagnostic Study (PDS) shall be carried out from the viewpoint of confirmation of deteriorated condition, cause analysis and examination of the solution corresponding to each causes.

The procedure of Step 3 is as follows.

### Step 3 Participatory Diagnostic Study (PDS)

During participatory diagnosis study, IO: Irrigators' Organization and Districts, ZIO should confirm deteriorated condition, and discuss the causes of problem.

The cause should be classified into matter concerned design such as selection of soil type, groundwater level and matter concerned construction such as insufficient backfilling, inadequate embankment, and so on. Moreover, the solutions corresponding to each causes shall be examined.

The work items of each step is as follows.

(1) Confirmation of deteriorated condition

(2) Cause analysis

In this step, the cause of deterioration shall be sorted by the matter related design and construction.

i. Design

- Selection of soil type
- Groundwater level
- Bearing capacity of basement

- Hydraulical design
- Structural design etc.

ii. Construction

- Insufficient backfilling, banking
- Inadequate embedment
- Insufficient plaster of mortar
- Poor sand cement ratio
- Inadequate supervision
- Lack of drainage facilities etc.

(3) Examination of the solution corresponding to each causes

After this procedure, several solutions shall be summarized as final solution.



### 3. Check points for better design and construction

#### 3.1 Design part

##### 3.1.1 Design of apron

[ Subject]

What is the matter which you should note on the occasion of a design of apron?

[ Countermeasure]

In case of designing a head work, several dimension of the apron should be secured to prevent the damages and malfunctions of facilities from floods. Then, required creep length, thickness and length of apron, etc. shall be decided using following calculation.

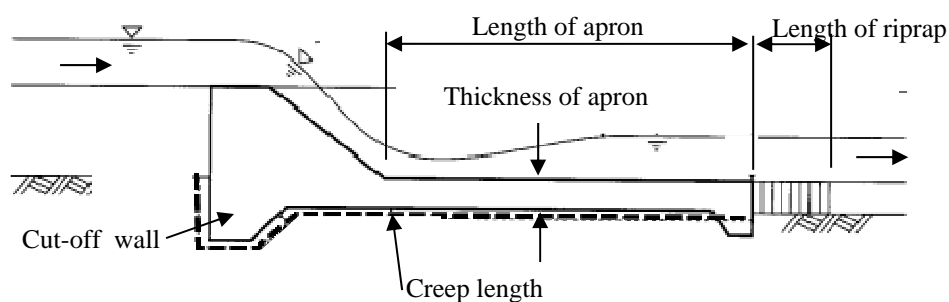

Figure 3-1 Model of the apron

Example of Kimbande scheme (Nyasa, Mtwara)



Base concrete washed away



Completed

[ Point of view]

(1) Required creep length for preventing excessive seepage

Creep length below must be ensured when a weir is constructed on the pervious foundation. Larger creep length estimated by the following equations (Bligh's method and Lane's method) is ensured.

< Bligh's method >

$$S \geq C \times H$$

S : Length of creep measured along the foundation face of the diversion dam, which differs from the actual percolation path. (m)

C : Coefficient which varies depending on the permeability of the foundation.

H : Maximum head difference at upstream and downstream sides. (m)

< Lane's method >

$$L \geq C' \times H$$

L : Length of weighted creep length (m),  $L = \sum l_v + 1/3 \times l_h$

$l_v$  : Creep length of vertical direction (inclination of more than 45°)

$l_h$  : Creep length of horizontal direction (inclination of more than 45°)

C' : Coefficient which varies depending on the permeability of the foundation

H : Maximum head difference at upstream and downstream sides (m)

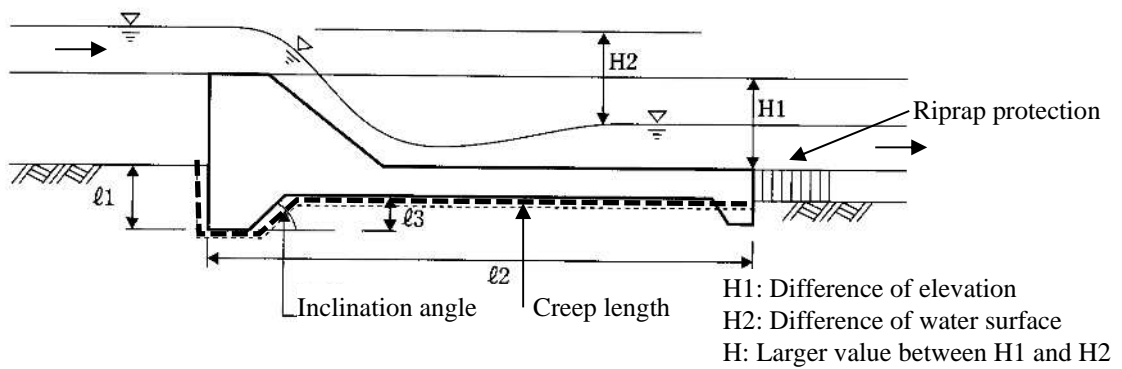

Figure 3-2 Profile of apron

H1: Difference of elevation  
H2: Difference of water surface  
H: Larger value between H1 and H2  
 $S = l_1 + l_2 + l_3$   
 $L = l_1 + l_2/3 + l_3$

Table 3-1 Coefficient values of C (C')

Foundation	Bligh's method	Lane's method
Silty sand or clay	18	8.5
Fine sand	15	7.0
Medium sand	-	6.0
Coarse sand	12	5.0
Gravel	-	4.0
Coarse gravel	-	3.5
Sandy gravel	9	-
Cobble stone with gravel	-	3.0
Rocks with cobble stone and gravel	-	2.5
Rocks with gravel and sand	4 - 6	-
Soft clay	-	3.0
Medium clay	-	2.0
Heavy clay	-	1.8
Hard clay	-	1.6

(2) Apron of downstream

< Thickness of the apron >

The thickness of the apron can be obtained using following equation so that the dam body have enough weight to resist the up-lift pressure.

$$t \geq (4/3) \times (\Delta H - H_f) / (\gamma - 1)$$

t : Thickness at any point (m)

$\gamma$  : Specific weight of material for apron

$\Delta H$  : Maximum head difference at upstream and downstream sides. (m)

$H_f$  : Water head loss at any point

4/3 : Safety factor

t<sub>2</sub> = 0.50m (general river)

t<sub>2</sub> = 0.60m (Pebbly river)

S : Whole creep length

S' : Creep length to any point

$$H_f = \Delta H / S \times S'$$

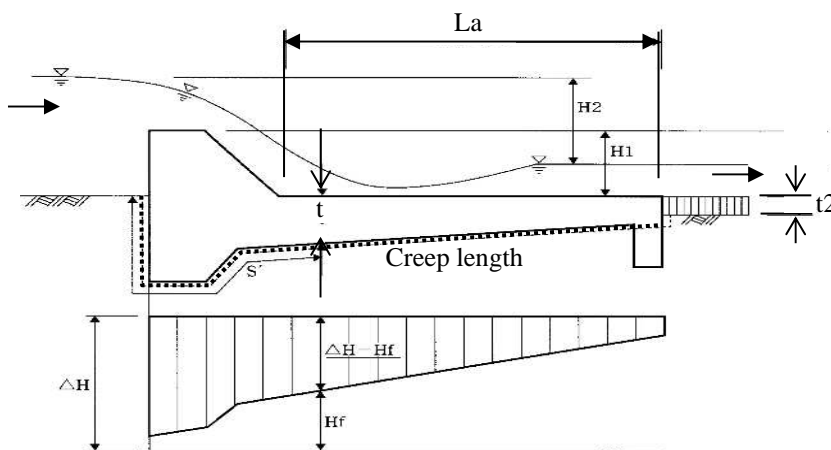

Figure 3-3 Thickness of the apron

< Length of the apron >

Length of apron is expressed by the following equation so as to protect riverbed erosion and scouring downstream of weir.

$$La = 0.6 \times C \times (D_1)^{1/2}$$

La : Length of downstream apron (m)

D<sub>1</sub> : Height from apron surface of downstream end to weir crest (m)

C : (Bligh's) C

### (3) Length of riprap protection

The length of riprap protection is estimated using following equation.

$$L = L_b - L_a$$

$$L_b = 0.67 \times C \times (H_a \cdot q)^{(1/2)} \times f$$

L : Length of riprap (m)

L<sub>b</sub> : Total length of apron (L<sub>a</sub>) and riprap (L) (m)

H<sub>a</sub> : Water level of downstream in dry season to top of the dam peak (m)

q : Amount of unit water flow at design discharge (m<sup>3</sup>/sec/m)

C : Coefficient values of Bligh's method

### (4) Cut-off

Cut-off wall to restrain the excessive seepage and to secure the safety the dam body by prevention the piping, obstruction wall against scouring of river bed caused by water flow shall be installed respectively.

As to cut-off depth installed at the end of upstream, similar depth of dam-up height (h) should be secured to prevent local scouring. Moreover, when the soil type of basement consists of fine sand, at least 1.5 times deeper than dam-up height shall be set.

Obstruction wall to protect the dam body against scouring of downstream shall be installed in consideration of the river bed situation, soil type, structure of riprap protection, and so on.

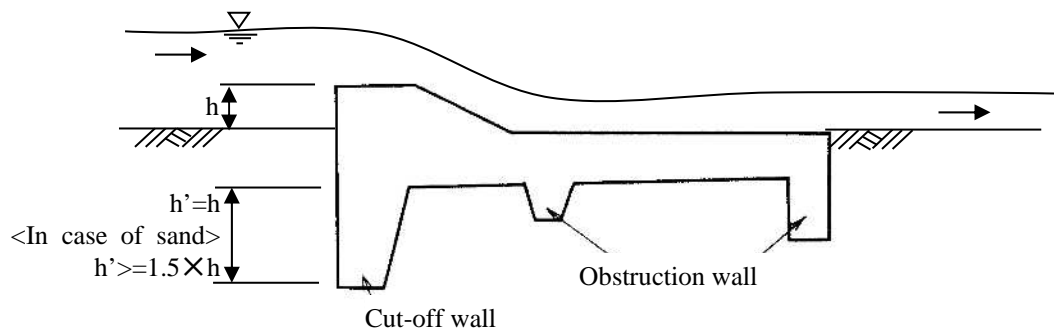

Figure 3-4 Cut-off wall and obstruction wall

### 3.1.2 Canal protection against flooding

[Subject]

What kind of measures are there to minimize the collapse of irrigation canals by the flood?

[Countermeasure]

Provision of mass concrete capping or concrete slab along the top of the lining is effective to prevent scouring behind the lining. Also stone pitching installed at the top of the canal is effective to prevent scouring. Stone pitching can increase roughness coefficient, thus flow velocity becomes low on the stone pitching portion.

[Point of view]

Various factors are related, and then collapse or the malfunction of facilities are caused. Moreover, there are many cases of deteriorated structure by scouring of the back soil.

Especially, lining canals are susceptible to be damaged by overflowing of floods from lateral direction of the canal.

Therefore, in the stage of the outline design, it is necessary to hear from farmers about the floods and to examine the field survey taking drainage measures into consideration.



Collapsed canals by overflowing of floods

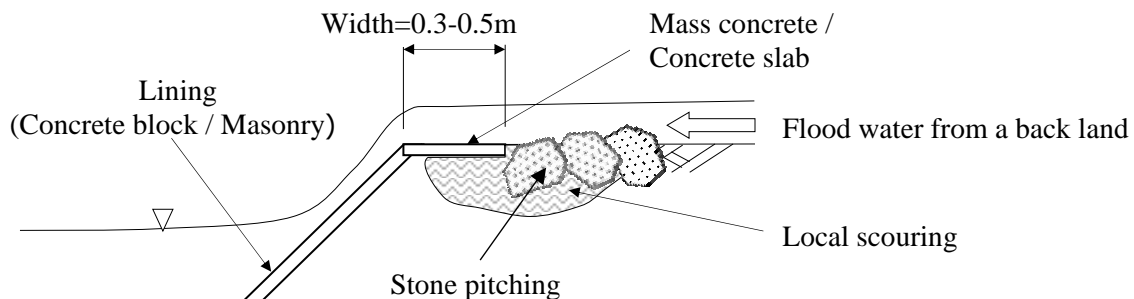

Figure 3-5 Protection of lining

### 3.1.3 Characteristics of black cotton soil

[Subject]

In case of black cotton soil, what kind of consideration is necessary?

[Countermeasure]

Side slope as 1:1.5 may minimize a collapse of the side wall of canals. In the case canal slope is protected with a concrete slab or masonry lining, replacement of surface portion with another soil may effective to keep the black cotton soil in stable moisture content, hence expanding and shrinking of the soil is minimized.

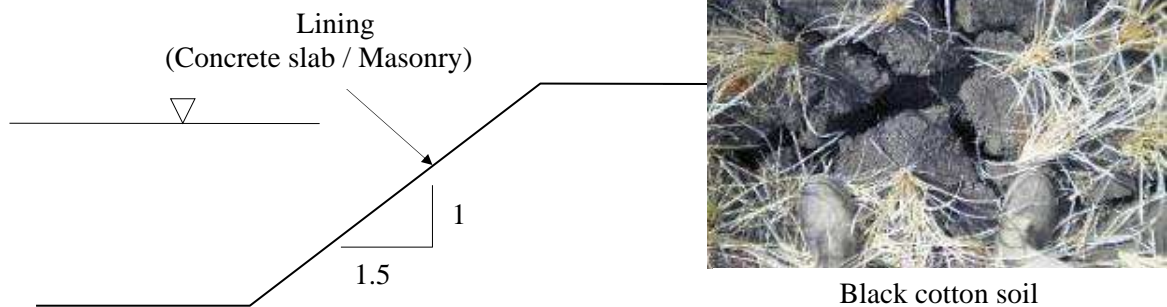

Figure 3-6 Side slope for lining canal

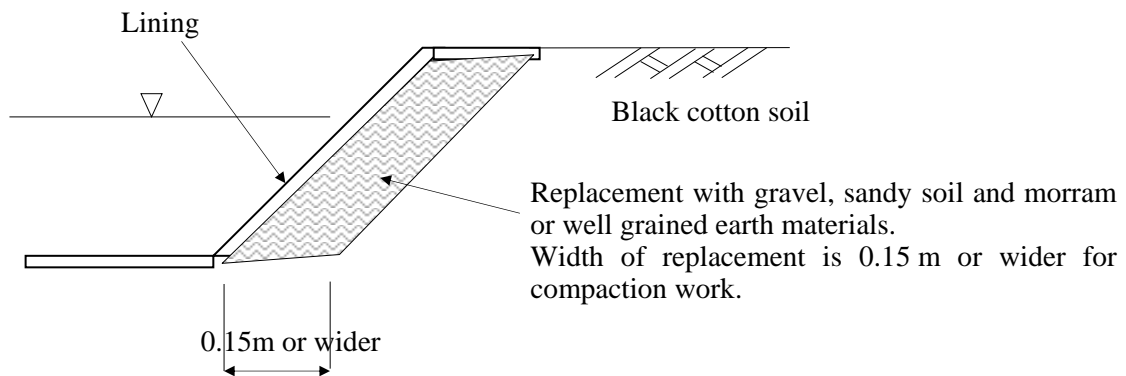

Figure 3-7 Replacement of backfilling

[Point of view]

Black cotton soil is a special soil in which there is a high content of expansive clay known as montmorillonite that forms deep cracks in drier seasons or years. Expansive soils occurring above water table undergo volumetric changes with change in moisture content.

Increase in water content causes the swelling of the soils and loss of strength and decrease in moisture content brings about soil shrinkage. Swelling and shrinkage of expansive soil cause differential settlements resulting in severe damage to the foundations, buildings, roads, retaining structures, canal linings, etc.

### 3.1.4 Depth of embedment of a structure

[Subject]

How much depth of embedment should be secured?

[Countermeasure]

The depth of embedment of a structure shall be determined based on the basement situation although influenced by the topography condition. Moreover, when the structure is installed in the river, necessary depth should be ensured to prevent scouring of river bed.

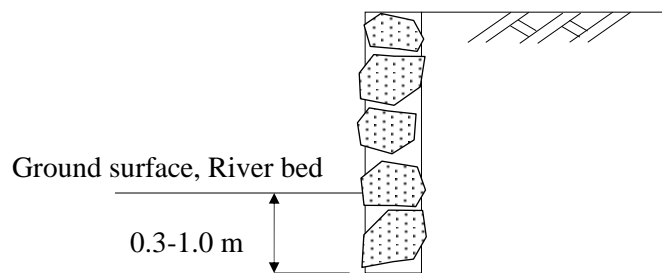

Figure 3-8 Embedment of Foundation

[Point of view]

In case the base is almost plane and there is no risk to be scoured by erosion or weathering, the depth of embedment shall be 0.3 m.

At the site where the front of base inclines and risk of scouring by erosion is supposed, the depth shall be 0.3 m and the width of banking should be ensured at least 1.0 m.

When the gradient of longitudinal canal slope is gentle, the depth of embedment of a structure shall be 0.5 m. Moreover, when the canal slope is steep and risk of scouring or damage by stone flow is supposed, 0.7 – 1.0 m of embedment should be ensured.

The base of retaining wall shall be embedded into ground about 0.5 m or more to prevent scouring of the riverbed. When the river flow velocity is fast, more than 1.0 m of depth of embedment shall be proposed.



Embedment before concrete placement

### 3.1.5 Base concrete work for canal protection

[Subject]

How much thickness of base concrete work should be considered?

[Countermeasure]

The thickness of base concrete should be secured corresponding to the basement condition and velocity of the water flow to prevent from scouring of wall foundation.

[Point of view]

The base concrete thickness of the canal shall be 0.15 m taking basement condition into consideration, beside 0.20 m should be ensured in case maximum velocity of water flow exceeds 3.0 m/sec. When the basement is not good, base gravel (thickness = 0.15 m) shall be employed if needed. Moreover, ground sill for the masonry structure is very important and the sill shall be made by concrete to support the upward load of the structure.

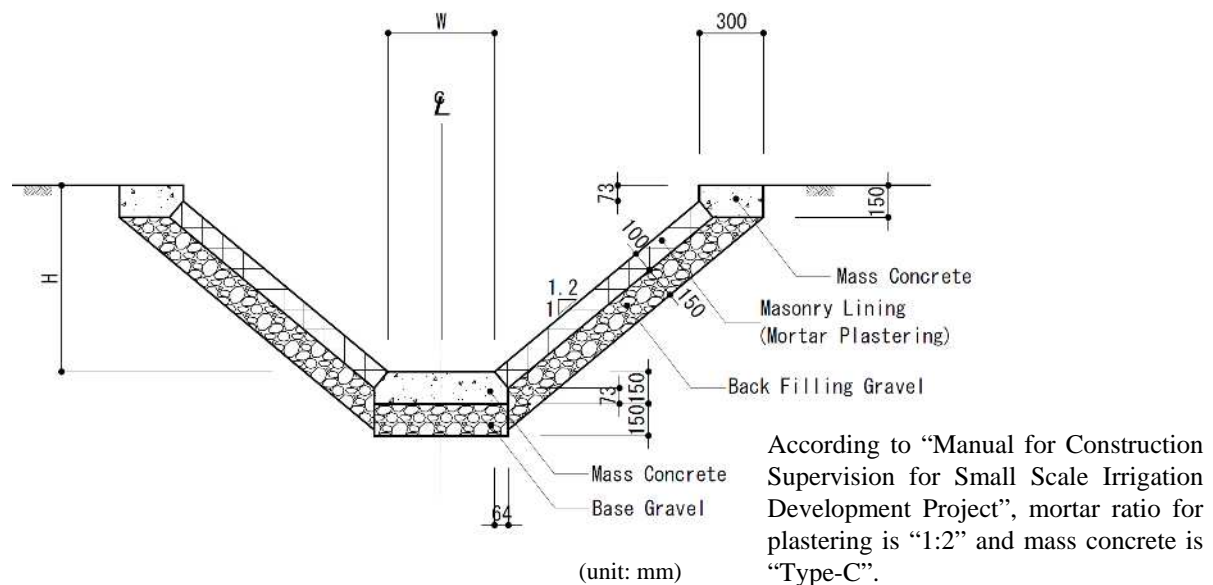

Figure 3-9 Drawing example of base concrete

It is worth to consider that wood can be used as a substitute for concrete to secure the stability because the corrosion of the wood rather does not advance in the water. When wood used as the sill of masonry, wood and wooden pile shall be placed as shown in Figure 3-10, and these materials should be united well with wire each other.

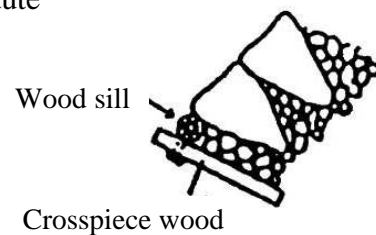

Figure 3-10 Example of woodn sill



### 3.1.6 Catch drain

[Subject]

What kind of case does the catch drain plan in?

[Countermeasure]

When an irrigation canal flows down along a contour line and it is unavoidable that the rain flow into the canal or beneficial area, catch drain should be installed at upper side of the canal or farm land.

[Point of view]

The catch drain is a canal to carry the outflow from areas other than the irrigated area directly into the drainage main river instead of flowing into the internal beneficial areas.

Catch drains that can safely remove the discharge during flood conditions shall be designed based on investigation results of the drainage area.

While the routes are located along the perimeter of the project area, they are frequently located inside of the bank in order to treat the seepage water.



Catch drain by farmers' contribution

Design discharge shall be decided based on precipitation and the basin area.

< Calculation example >

$$0.1 \text{ m}^3/\text{sec}/\text{km}^2 = 8.64 \text{ mm}/\text{day}$$

(In case precipitation rained per a day will flow down in a day from the farm land.)

When 40mm/day is set as targeting precipitation, design discharge will be  $0.46 \text{ m}^3/\text{sec}/\text{km}^2$ .

### 3.1.7 Effective good use of existing structure and material

[Subject]

What's the matters that require attention when reuse of the materials?

[Countermeasure]

In the rehabilitation work, examination for the reuse of the materials, such as concrete wreckage or the cement brick as backfilling, should be carried out from the viewpoint of cost reduction.

[Point of view]

The rehabilitation work starts from the demolition of deterioration structure and much scrap occurs. On this occasion, some scrap can be used as a material.

As to masonry, collapsed natural stone must be used effectively. Reuse of the stone contributes to cost reduction and shortening of the construction period.

But it is necessary to remove the mortar and the soil which attached to the surface of the stone because the strength as a structure shall be decreased.

Similarly, reuse of these materials, such as masonry and natural soil, as a composition of the concrete should be avoided because the materials have possibilities to cause a strength drop by the contamination of soil and sand.



Concrete wreckage used as backfilling

### 3.1.8 Unlined canal

[Subject]

In case of unlined canals, what kind of consideration is necessary?

[Countermeasure]

It is important to set the velocity of canal flow less than the maximum allowable velocity to avoid the scouring of basement and erosion of side slope. Moreover, at the point where the velocity shall increase temporarily such as downstream of division structure and drop structure, careful examination corresponding to the soil type is needed.

[Point of view]

In Tanzania, unlined canal occupies much portion of irrigation and drainage canal because construction cost is low and construction period is short in comparison with other canals such as concrete slab lining or masonry lining canal, and so on.

On the other hand, this type of canal has some weak points such as easiness to be eroded.

Moreover, unlined canals are basically constructed on two types of conditions; namely on embankment and on natural ground (mostly canals constructed by digging or excavation). These conditions may differ in occurrence caused in canal degradation, and sometimes affect to seriousness in social impacts. Large impacts may require urgent countermeasures.

For example, in the embankment canals social impacts are considerably large, when embankments are breached under degradation such as piping. In the canals excavated on the natural ground, there are cases that land and roads along the canals are damaged by excavation or erosion on their side walls.

So, when the countermeasure according to the problem shall be examined, taking constructed condition into consideration is necessary.



Erosion of side slope



Scouring at the downstream of division structure

### 3.1.9 Consideration to a way of cattle

[Subject]

About cattle traffic, what kind of consideration is necessary?

[Countermeasure]

In case of canal designing, traffic course of cattle shall be grasped beforehand and installation of small pass or bridge for cattle have to be considered.

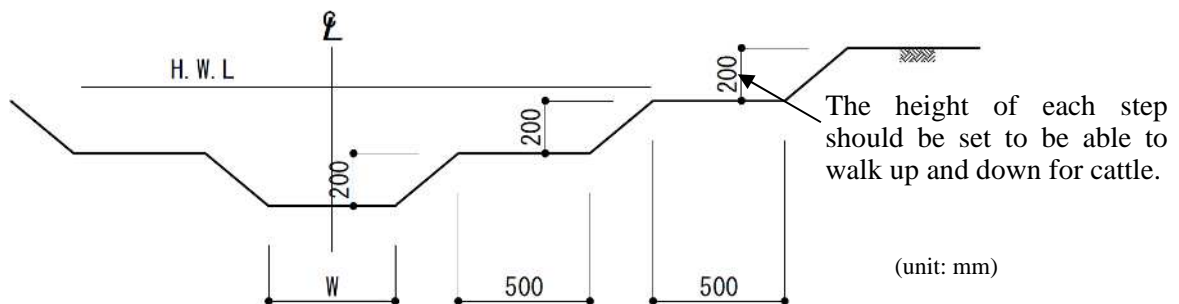

Figure 3-11 Image figure of cattle pass

[Point of view]

Cattle are raised widely in Tanzanian rural area, and they go to feeding grounds from farmhouse every day. But they cannot come and go freely after construction of canals made by masonry or concrete slab and there are some cases that the side wall part of canal damages by the traffic of the cattle.

So, examination of the traffic road for not only farmers but also cattle shall be needed, and such cattle pass mentioned above figure will provide a drinking fountain.

## 3.2 Construction part

### 3.2.1 Earth work

[Subject]

What is the point to keep in mind in earth work?

[Countermeasure]

The earth work is the basis of construction and is also difficult to obtain the planned strength of soil. Since the main factor of the difficulty shall be moisture contents, dry work which is executed in the condition of suitable moisture control should be considered.

Moreover, the strength of structure shall be decided based on the foundation strength, compaction work at backfilling and banking is very important.

[Point of view]

The earth work in construction can advance from excavation, cut off trench, slope adjustment, back filling, banking and compaction, etc. with a series of flow. Since the nature of the soil changes big by included moisture content, groundwater, spring water and rainwater, dry work should be considered.

Drainage facility plan shall be developed in order to prevent ponding due to rainfalls, spring water, etc. at all times during construction execution. Particularly, the treatment for foundation ground of structure shall basically use the method of construction in the complete dry state, and the treatment method shall be sufficiently studied before its implementation.

#### (1) Excavation and trenching

The excavation shall be performed to secure the required dimension of structure within the practical extent by digging down to the prescribed level without loosening other part as much as possible and with evenly finished surface as well. When changes in the design parameters are significant enough to raise suspicion regarding the bearing capacity of foundation ground, etc., the safety of structure must be confirmed.



Excavation at the canal construction

When over digging across the formation level, backfill using gravel and sufficient compaction is necessary.

#### (2) Slope finish

Slopes shall be finished with the gradient specified in the design documents. When the loss

of slope stability is possible, or when the construction cannot proceed due to exposed rocks and boulders, or due to spring water, the design parameters shall be reviewed to confirm the safety.

(3) Backfilling

While the properties of backfill soil conforming to the design conditions shall be used, various things must be removed before starting the work. And during its implementation, the backfilling must be performed with due caution not to impact the structure.



Backfilling at the culvert construction

The structure shows its function in a body with the back earth. When the compaction functions sufficiently, encroachment is prevented and it contribute to longer life of the structure.

On the other hand, recognition about the importance of back filling and compaction seems to be not enough in Tanzania, and as for the case which soil is only put in is also observed.

The phenomenon such as crack and collapse of a structure start from washing out of foundation mainly and it should be understood that insufficient back filling is major cause of them.

It's effective that the engineer practices and shows the method of back filling and compaction work. The procedure of the series of work scattering soil with thickness of 15 cm, watering (adjustment of hydration), and ends with compacting using lunge tool (hard tree) or compactor.

Moreover, the consolidation may happen with shrinkage in some period after back filling or compaction because of removal of water in earth. It's necessary to put the soil into the portion of differential settlement in daily maintenance work.

(4) Banking

While the material used for banking shall conform to the design conditions, the banking shall be finished with flat surface and the gradient specified in design documents. Also, when banking is performed on ground with steep slope, the adhesion between banking and existing ground must be achieved by measures such as bench cuts, etc. in order to prevent slides.



Banking at the road construction

When banking is performed over soft ground or ground with high groundwater level, drying of the banking bed must be achieved by taking measures such as installation of drainage trenches as early as possible. The banking work under this situation shall be performed with due caution including monitoring the settlement status, etc.

Banking work must be suspended when situations as described below occur, and actions appropriate for the extent of situations must be taken.

- i. Underwater banking work has occurred.
- ii. The moisture content of material is no longer appropriate due to rainfall.
- iii. The banking foundation ground does not have the bearing capacity specified in the design documents.
- iv Unforeseen settlement or slide has occurred during construction execution.

#### (5) Compaction

Compaction work shall be performed properly in accordance with the compaction specification (machine type to be used, layer thickness, number of rolled compactions) predefined in design documents in consideration of the moisture content and weather conditions of the site.

Compaction of embankment is very important to prevent leakage from the canal. However, during dry season clay type soil becomes very hard and effective compaction will not be possible. Watering to saturate soil will be necessary to keep optimal moisture contents of soil for good compaction.

Normally, if soil has sufficient moistures, compaction by feet will be effective. But when soil becomes dry and hard, machinery or compactor will be necessary to effect good compaction.

Compaction should be continued during maintenance period. It will take a few years for embankment to become stable and firm.

During maintenance period, irrigation and drainage canal and maintenance/farm road should be maintained and repaired when necessary, the embankment should also be strengthened by adding silted soil from canal on the embankment and properly compacted.



Compaction at the dam construction



Compaction at the road construction

### 3.2.2 Concrete work

[Subject]

What is the essential point for making high quality concrete structure?

[Countermeasure]

The nature of concrete changes in short term, proper treatment which should be applied in each steps is necessary. Especially, since the concrete strength shall be decided within one month, tasks executed on site (from placement to curing) is very important.

[Point of view]

Adequate construction control must be provided with due attention paid to each construction execution stage in order to produce a concrete with good quality. Once the materials to be used and the mix, etc. are defined, the execution of concrete works normally follows the sequence shown as following figure in general.

The construction sequence in concrete work is as follows. Concrete work flows from material calculation as in-plant tasks to curing as tasks executed on site.

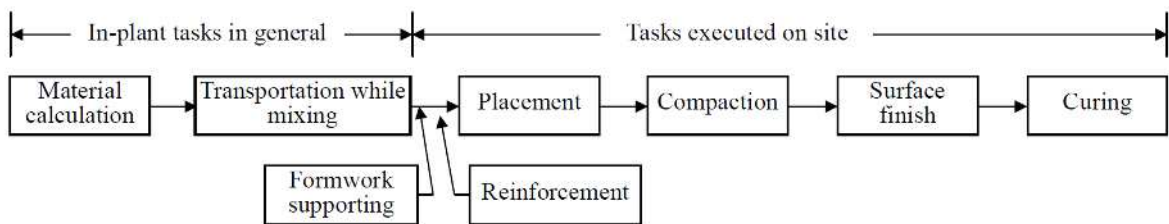

Figure 3-12 Construction sequence in concrete works

These tasks are mutually related, and if the outputs of tasks before and after are not sufficiently satisfactory, the final product desired cannot be obtained. Thus, a rational planning must be developed to proceed with the entire construction project in fully controlled manner. Additionally, the consideration points for concrete works are as follows.

#### (1) Placing

When concrete is placed continuously for a high wall, the consistency and placing rate of concrete shall be adjusted to minimize the separation of materials during placement and compaction of concrete. Also, the placement in one block shall be performed in such a way that the concrete surface is approximately level, and the height of one layer shall be 40 cm or less as a general rule.

When the concrete placement is performed in two or more layers, the upper layer concrete shall be placed before the lower layer is hardened, and the placement of concrete shall be



performed in succession until completion of the concrete placement within one block.

## (2) Compaction

Concrete must be adequately compacted so that the concrete can be packed leaving no space around reinforcing bars and in every corner of formwork. While vibrators (internal/form) are generally used for compaction, the bar-type vibrator is used for canal structures of relatively small scale.



Void caused by insufficient compaction

The degree of compaction can be assessed by examining situations such as the leakage of concrete paste from form, reduction of concrete volume, surfacing of mortar or water.

## (3) Construction joint

While it is desirable to avoid construction joint as much as possible because it creates structurally weak point. Particularly, in the case of plain concrete, the joint must be strengthened by some means such as inserting an appropriate steel material.

Shortcomings of construction joint include the following.

- i. It lessens the compressive strength due to difficulty in integration of the new and old concrete.
- ii. It causes leakages when the construction execution is not perfect.
- iii. In the course of concrete hardening, the new concrete is prevented from shrinking due to restraint imposed by the old concrete, causing cracks, internal stress, compressive stress in the old concrete, and tensile stress in the new concrete. For this reason, the treatment of construction joint must be executed to produce sufficient bonding with the old concrete by removing the laitance or thin paste layer developed on the concrete surface.



Cold joint caused by inadequate manner

## (4) Curing

Concrete is exposed to detrimental effects such as low temperature, drying, sudden temperature change, etc. after it is placed. Therefore, the concrete must be kept wet and the

optimum temperature must be maintained during the cement hydration period so that crack occurrence and reduction of compressive strength due to moisture loss are prevented.

It is necessary to maintain the concrete in sufficiently wet condition under appropriate temperature for a certain period after it is placed so that the hardening action of the concrete placed is fully developed and crack occurrence is prevented as much as possible.

Concrete must be protected from vibration, impact shock, and load that may be applied during hardening process. In order to prevent the concrete not fully hardened from damages such as cracks due to impact shocks or excessive loads, care must be taken not to place materials, etc., or to drop a heavy load on the concrete already placed.

<Reference>

i. Wetting/drying and compressive strength

When the concrete strength is dependent on the strength of cement paste itself, the hydration of cement must be fully developed to establish the condition for the development of hardening by crystallization. For this purpose, it is necessary to keep the concrete under wet condition to prevent the moisture content from dissipation, and most ideally, it shall be immersed in water.

ii. Humidity and compressive strength

The range of temperature for concrete placement shall be 25°C or under in hot weather and 10 - 20°C in cold weather, as a general rule. Also, the concrete after placement in each case must be maintained under the temperature suitable for curing (4 - 25°C) for the prescribed number of days.

Generally, when the temperature (4 - 25°C) is exceeded during placement or curing of concrete, it is often to sustain adverse impacts such as crack occurrence in addition to delay in strength development or insufficient strength growth.



Hexagonal cracks caused by placing in high temperature condition

(5) Form

Forms and supports, in addition to their own prescribed strength and rigidity, must be of quality to ensure correct position, shape, and dimensions of the structure completed.

Additionally, forms and supports must not be removed until the concrete of structure reaches the strength required to support the dead weight and loads applied during construction execution.

### 3.2.3 Masonry work

[Subject]

What should we do to install the masonry structure with high durability?

[Countermeasure]

The strength of masonry structure shall be determined whether unity as a structure by mortar plastering is secured or not. Therefore, supervision of masonry work should be performed carefully, and confirmation of sufficient mortar plastering is necessary.

[Point of view]

The masonry construction is employed most in Tanzania, and insufficient mortar not filling into inside and back side and being given only surface of masonry is the most problem of this structure. In this case, the collapse starts immediately after building because stones are not combined.

It's necessary to confirm the construction process such as filling mortar into the inside of masonry while shipping stone and starting the wall after completion of foundation with engineer, contractor and farmers at the site.

Masonry canals keep their sections in mass bodies shaping by stones. Accordingly, they develop deformation, in many case of transformation, tilting, meandering and deficits caused in subsidence, collapse and hollowing of their foundation. They develop more deformation when stones are connected to others.

Gaps between stones should be carefully assessed, when washing out of backfilling soils at canal bottom, succeeding subsidence, increasing soil pressure, surface water inflow and unstable foundations develop them, Progressiveness on such phenomena should be monitored.

Moreover, as this type of canals has absolutely complex compiling to shape its structural body, the deformation is expanded on it. Attention should be put on wider zone, i.e. extending to surrounding areas and including part of canal bottom (mainly scouring).



Masonry lining canal  
(Behekala scheme, Igunga, Tabora)



Deficit of masonry caused by  
washing out of backfilling

< Reference: quoted from “Chapter 5\_Quality Control” of “Manual for Construction Supervision for Small Scale Irrigation Development Project for District Agricultural Development Plans” >

a. Placement of Wet Stone Masonry Works

The wet stone masonry shall be placed in accordance with the following manner:

No.	Work item	Explanation
1	Mixing of Mortar	The mortar shall be mixed with the following volume proportion of cement and sand: i. Joint of masonry = 1:4 ii. Plastering and pointing = 1:2
2	Moistening Stone	The stone shall be moistened before placing.
3	Filling Mortar & Placing Stone	The joint mortar shall be sufficiently compacted by the trowel and the stone shall be struck and consolidated by steel hammer  
4	Procedure of the Wet Stone Masonry	The wet stone masonry shall be pushed forward in the next procedure.  

Figure 3-13 Masonry Works

### 3.2.4 Keeping materials tidy and in order around construction site

[Subject]

What is the point that is important to secure security and quality?

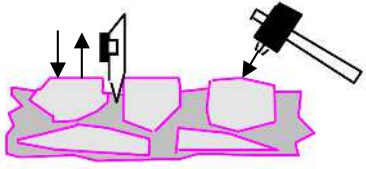
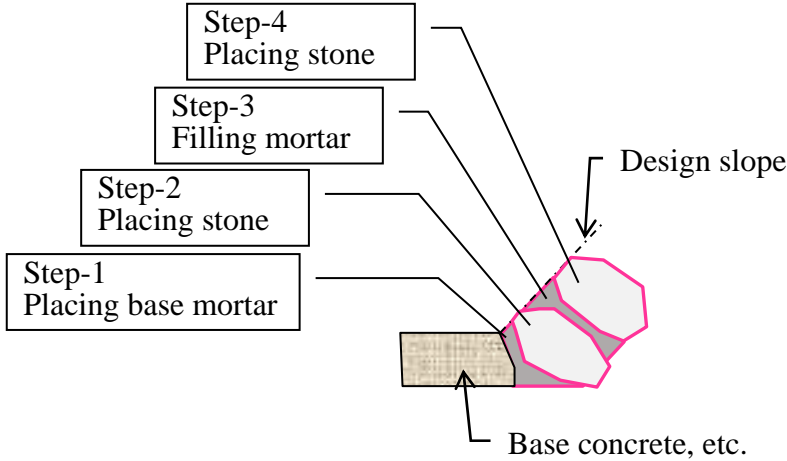
[Countermeasure]

Practice of keeping materials tidy up at the construction site prior to daily work should be performed. Not only safety is secured by these measures, but also the increase in profit by preventing loss of the material is anticipated.

[Point of view]

Keeping materials tidy up around construction site and arranging all of them for effective construction in mind are necessary. In addition, it is concerned about not only unity of the concrete being spoiled when alien substances such as a chip of wood or the vinyl get mixed with the structure, but also causing deterioration of the concrete and the rust of reinforcing bar by rainwater invading along an alien substance.

To secure strength and service period of the whole structure, it is essential to sort, accumulate and keep the materials by appropriate method.

#### (1) Safety management has top priority

There is various dangerous matter in the construction site, but the accident resulting in injury or death must be prevented. At first, the construction work cannot be continued when a serious accident occurs and it is necessary to take measures so that the similar accident does not happen by all means.

The basics of the rearranging is not only throwing away useless things but also keeping the necessary things at suitable place.

#### (2) Improvement of work and production efficiency

Work efficiency and production efficiency shall improve by removal the waste through rearranging order thoroughly. For example, "get rid of waste in search of a thing"; "get rid of waste of the loss of the product"; "secure work



Keeping materials tidy up



Safety management in the construction

space so that production efficiency and accuracy shall improve". Production speed will rise and can make time, as a result.

### (3) Procedure of keeping materials tidy

Firstly, the plan should be made. When rearranging order, putting the unnecessary things in order together to have to never do.

Next, it is important to decide a place of each material. There is various way to divide the materials with size, use frequency or genre and so on, the best way shall be keeping a thing near a place to use because the loss of time with the movement shall be reduced.

At last, preparation of safekeeping map has to be made in order that rearranging work can be carried out anytime. There is no waste of time when everyone related construction knows where the materials are beforehand.

### 3.2.5 Installation of the construction guide bar

[Subject]

What should we do to finish the construction work in section according to the plan?

[Countermeasure]

It is important that reproduction of dimensions shown in the design drawing locally to make an object of the construction with precision. The construction guide bar shows the next stage of work procedure to the supervisor and person concerned.

[Point of view]

The construction guide bar is indispensability for accomplishment of the construction management that is complete based on the inspection of the design documents and specifications in such as canal construction.

Prior to construction start, installation of the guide bar indicating the design height and width, gradient each station points should be carried out.

In installation of guide bar, the collations of the design level becoming basic of the guide bar such as design vertical section figure, figure of cross-section and structure should be performed before work.



Setting the guide bar for side slope arrangement

Example of arranging the earth work procedure (banking and slope finish) using guide bar is as follows;

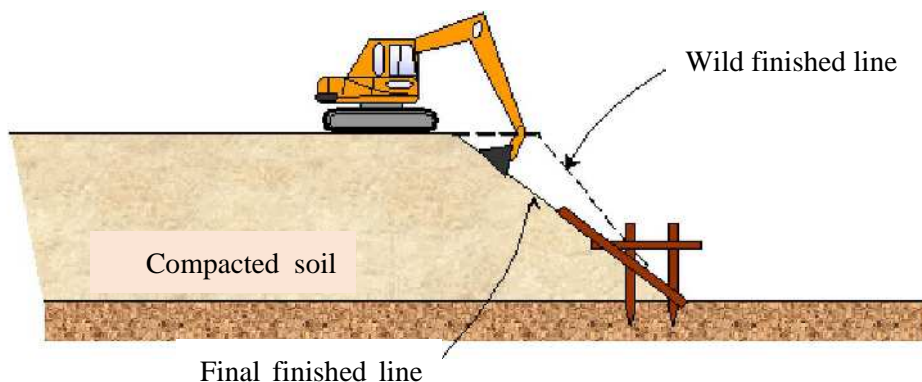

Figure 3-14 Image of earth work procedure

The guide bar is established at the position of laying earth on the ground and cutting work at an appointed incline shall be done after wild finish with a steeper gradient of slope.

### 3.2.6 Supervision of construction

[Subject]

What is the role of supervisor?

[Countermeasure]

The supervisor should act as the representative of the construction. Whole data and information concerned shall be accumulated for effective implementation of the construction.

[Point of view]

Role of supervision staff is important for proper and smooth implementation. The main points to keep in mind of the verge are as follows;

- For the completion of the satisfactory construction, a fair price should be paid.
- Does the constructor implement the construction based on contract, design drawings, specifications, etc.?
- Does the contractor properly implement process control, quality control and safety management and comply with conditions?
- When there is possibility of disconfirmation after completion of construction, following correspondence shall be necessary.
  - + on-site witness
  - + confirmation
  - + inspection
  - + consultation

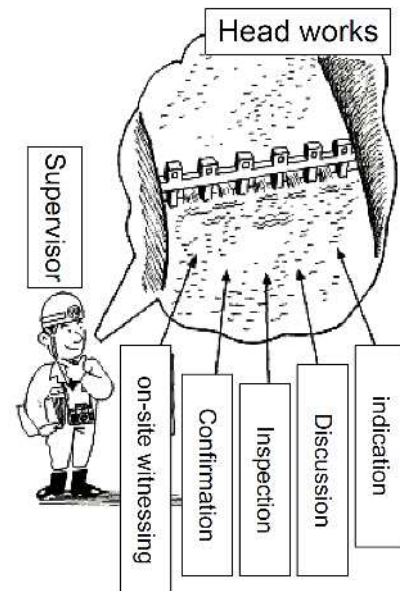

Figure 3-15 Role of supervisor

- When the work is completed, client conduct a completion inspection, and the construction should have reached the level of expected outcome.
- Understanding the objective and contents of the construction.
  - + Understand the importance of construction work in the project plan.
  - + Get familiar with related materials such as design contents, design drawings, and specifications.
  - + It is important to know well about local situation.
- Eliminating construction mistakes
- Survey result, on-site witness, confirmation, contents of discussion and instruction is noted on filed note, recorded (when, where, what, who) to supervisor diary.
- Reporting, communication and consultation to the team leader must be carried out properly.
- Relevant documents for construction must be always checked and organized.
- Properly correspondence to changing of the design according to the local situation.



### 3.2.7 Records of construction

[Subject]

How should we record the enforcement situation of the construction?

[Countermeasure]

Maintenance of the documents of construction such as completion drawing and photograph, the data of used materials, etc. are very important so that construction progress can be confirmed even if after construction completion.

In addition, as to invisible part which cannot be observed at the time of inspection, it is expected to take a lot of photograph from various angle as much as possible so that person concerned can confirm the construction situation with it.

[Point of view]

Photography example is as follows;

#### (1) Canal basement

- The photograph needs to be able to confirm not only the result of dimension measurement at this point but also backward continuity in an angle.
- When it is necessary to perform quality management, the records of confirmation work shall be attached.



Finishing excavation

#### (2) Concrete block lining slope

- The photograph should be taken to understand the situation and the thickness of backfilling, and the measurement result shall be attached on black board.
- It is better that the angle of the camera will be set in a right angle to confirm the thickness.



Finishing backfilling

### (3) Basement of structure

- Because of using pin pole and measuring rods, both of thickness and width can be confirmed.
- It is better if the height of basement surface and relation to surrounding structures can be made out from this picture.



Finishing basement

### (4) Reinforcing bar setting

- The setting situation of reinforcing bars and interval between bars can be observed.
- When there are many marking points, additional photograph from different angle shall be needed.
- If this is important structure such as head work or bridge, the confirmation of supervision staff at the site is necessary.



Finishing reinforcing bar setting

#### 4. Example of cause analysis (Case study of Phase I)

##### 4.1 Head Work

##### 4.1.1 Base concrete washed away (Kimbande, Nyasa, Mtwara)

Cause	Solution
Piping (excessive seepage) caused by cut off walls was being too short.	Install cut-off wall upstream (2.0m), middle cut off wall (2.0m) and downstream cut off wall (0.7m) considering the soil type (sand) which brings excessive seepage.
Hydraulic jump-thickness of the base concrete was very small (almost 20cm) to withstand flood power.	Increased thickness of base concrete with stony masonry to prevent seepage to form stable foundation and to prevent hydraulic jump.
Construction management / poor supervision to the contractor.	District is empowering PC to check the quality of the concrete work. District has conducted dimension control especially length of cut-off walls, depth of base concrete using control sheet.



Base concrete washed away and hydraulic jump broken by piping and flood power.



Planned longitudinal cross-section. 3 types of cut-off wall were designed considering soil type (sand).



Placing the base concrete with stone masonry.



#### 4.1.2 Side wall collapsed (Kimbande, Nyasa, Mtwara)

Cause	Solution
Depth of the embedment was affected by scouring / erosion done by flood water	Increased depth of the embedment to 1.2m from the base of downstream apron.
Depth and width were not enough to protect from piping considering the soil type (sand soil).	Used trapezoidal shape and retaining wall for the side walls and 1.5m as a base.



Left side wall collapsed by scouring / erosion occurred by flood water. (View from downstream)



Increased depth of the embedment to 1.2m from the base of downstream apron.



Dimension (depth of the wall) is taken after completion of concrete work.

## 4.2 Canal

### 4.2.1 Bulging of main canal sides and cracks on slab joints (Mbalangwe, Morogoro, Morogoro)

Cause	Solution
Infiltrating rain water besides the canal top on the left canal bank.	Construction of non silting, non eroding left collector drain along the main canal with adequate dimension, bed slope, (0.001 to 0.0005) with well compaction and lead water into a drift.
Inadequate top concrete cover.	Provision of adequate top concrete 200mm wide x 100mm thick.



Bulging of main canal sides and cracks on slab joints caused by heavy rains with floods. (over-topping)

Planned cross-section of main canal with collector drain.

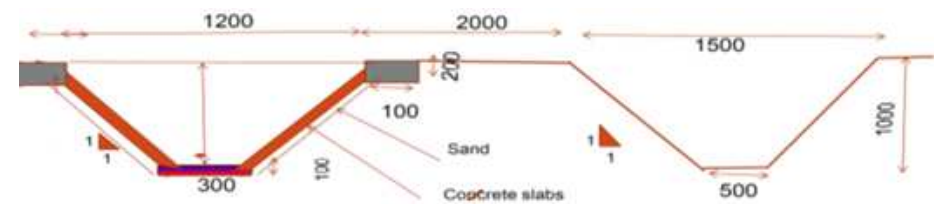

Farmers contribute to cleaning work of collapsed canal.

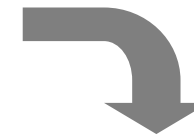

Completed.



#### 4.2.2 Collapse of main canal slabs (Mbalangwe, Morogoro, Morogoro)

Cause	Solution
Failure of catch drain embankment.	Increase dimension of catch drain; select impervious soil (30% clay <0.002 mm and/or silt (0.02 to 0.002mm) +70% sand (0.02 mm to 2mm)



Participatory diagnostic study was executed by District staff and IO.

Planned cross-section of catch drain

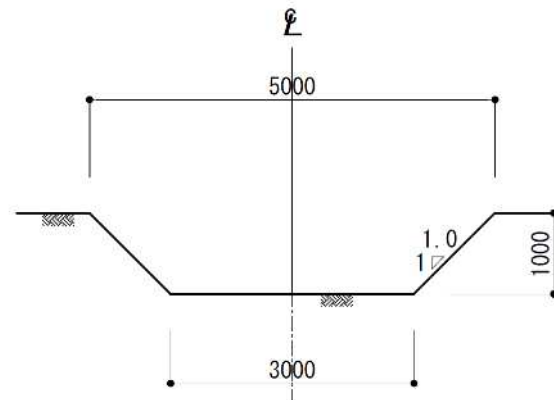

Removal work of sand on catch drain with farmers' contribution.

#### 4.2.3 Destruction of main canal (Mtawatawa, Liware, Mtwara)

Cause	Solution
Soil type (black cotton soil), poor compaction.	Import and compact good soil rather than black cotton.



Backfilling was imported and compacted using good type of soil.



Cracked canal side wall caused by black cotton soil and poor compaction



Note: Black cotton soil (Vertisols: Name of Soil Orders in Soil Taxonomy)  
 The central concept of Vertisols is that of soils that have a high content (>30%) of expanding clay known as montmorillonite and that have at some time of the year deep wide cracks. They shrink when drying and swell when they become wetter. The shrinking and swelling of Vertisols can damage buildings and roads, leading to extensive subsidence.

#### 4.2.4 Some fields do not efficiently get water (Mtawatawa, Liware, Mtwara)

Cause	Solution
Some level in the fields are higher compared to canal top bank level	To rise canal bed level by 0.20m and top bank level by 0.25m.



Some fields do not get irrigation water efficiently by differential settlement of the canal. Zone and District staff confirm the height of the canal bed and longitudinal slope.



After survey work, IO decided to rise canal bed level by 0.20m and top bank level by 0,25m respectively. After that, backfilling was compacted enough to keep good condition for facility.





#### 4.2.5 Collapse of sides of main canal (Minepa, Ulanga, Morogoro)

Cause	Solution
Poor cement/sand ratio	Stone masonry joints: cement sand ratio to be 1:3
Inadequate supervision during construction	Provide daily supervision by Irrigation technician and PC
Inadequate thickness of base	Increase thickness of base (5cm => 10cm thick base)
Wall doesn't have a plaster	Plaster canal walls
Seepage of water behind the abutment wall	Fill the seepage path with stone masonry



Side wall of main canal constructed by masonry collapsed. Some factors are picked up as the cause of this problem through the cause analysis.



Construction work started from cleaning of sedimentation, and progressed with farmers' contribution



#### 4.2.6 Scouring along the footpath (Kiyulini, Mwanga, Kilimanjaro)

Cause	Solution
Structures were not protected	Side protection of structures with concrete blocks. Soil backfilling and compaction for the constructed structure.



Since foot bridge was not protected from scouring, irrigation water was logging and seepage occurred.



Construction works were pushed forward under supervision of technician.

Planned cross-section

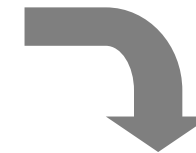
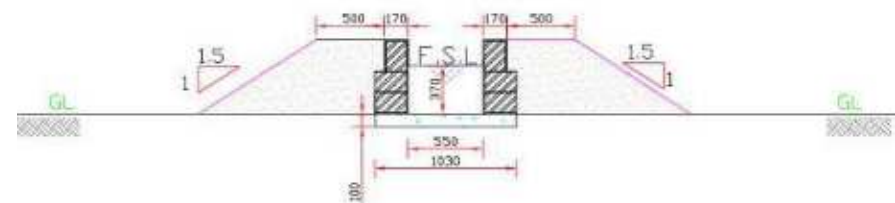

Completed.



#### 4.2.7 Collapse of secondary canal (Dakawa, Mvomero, Morogoro)

Cause	Solution
Flood water from adjacent pond to the main canal through cross drain	Improve the capacity of secondary drainage canal (activity by farmers)
Over loading of irrigation canals with irrigation water.	Improve the system up to tertiary canal/drain and farm bund (phase I) and continue 5000 meters tertiary improved.



Secondary canal collapsed by flood water from adjacent pond. It was clarified that 5 Diversion boxes are out of order after Participatory Diagnostic Study.



Improved tertiary canals with farmers' contribution.



Rehabilitation work completed at the division box.

4.2.8 Vertical walls of the distribution boxes collapsed to the inside. (Igongwa, Misungwi, Mwanza)

Cause	Solution
Poor construction - poor sand cement ratio were used.	Application of proper ratio of materials as per new design.
Soil type (Black cotton soil)	To construct reinforced concrete structures supported by blinded concrete and compacting morram behind those vertical walls.
Insufficient thickness of the foundation	Application of proper detail designed which will take consideration proper dimension control, good concrete ratio, frequently curing not less than 28 days.



Vertical walls of the distribution boxes collapsed to the inside due to poor construction and abnormal earth pressure caused by black cotton soil.



Reinforcing bar setting on the well compacted foundation.



Compacted using crashed ole structure and morram beside the walls

#### 4.2.9 Collapse of division box (Minepa, Ulanga, Morogoro)

Cause	Solution
Flood water	Reconstruction of new division box (activity by farmers)



Collapsed division box is selected as main problem after Participatory Diagnostic Study.



Farmers constructed division box using bricks.



### 4.3 Others

#### 4.3.1 Frequent bleaching of main canal banks (Lusu, Nzega, Tabora)

Cause	Solution
Poor quality earth fill soil (permeable) used to form the canal bunds.	Reconstruction of the broken main canal bund by use of suitable material.
Narrow main canal with low capacity.	Widen the main canal
Low capacity of culvert few meters downstream the spillway.	Reconstruct the bridge with adequate capacity
Side spillway is inadequate (small)	Widen the spillway to increase capacity.



The scheme conveyance system was seriously destroyed by floods.



The main canal was widening by farmers' contribution.

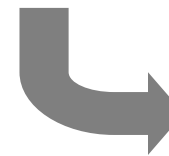

Additional spill way (right side) completed.

#### 4.3.2 Destruction of vented drift (Bkigi, Maswa, Mwanza)

Cause	Solution
The overflow of the water caused by high flood	To add another line of the concrete pipes with the same dimension.
The seepage due to the scoring of water mainly on some parts of the foundation	The construction of the drift foundation must comprise of hardcore, concrete and stone masonry and plastering should be used on wing walls.
Improper construction of the top panels.	The construction of the concrete on the carriage way/top panels at the drift should be of the reinforced concrete.



Vented drift with one line of concrete pipe culvert was destructed by the overflow of the water.



Two concrete pipes will allow more water to pass through and prevent overtopping. Moreover, the wing walls which prevent scouring hence no seepage were installed at the entrance of the pipes.